



# AnaSem

Analog Semiconductor IC  
MRX1518HNA

#07-11

## CMOS MR MAGNETIC SENSOR SWITCH

### Feature

- CMOS+MR Monolithic Structure
- SMD SON-4 Package: 2.0 × 2.1 × 0.6mm
- Low current consumption: 1.6 μA/1.8V
- High-Sensitivity MR sensor: 1.5mT/Typ
- Magnetic Direction: Both direction/CMOS inverter one output
- Detection Magnetic Field: Horizontal direction of package (electrode parallel both direction)
- Operating Temperature Range : - 40 ~ + 85
- Operating Voltage Range : 1.6 ~ 3.5V

### PIN/Block Diagram

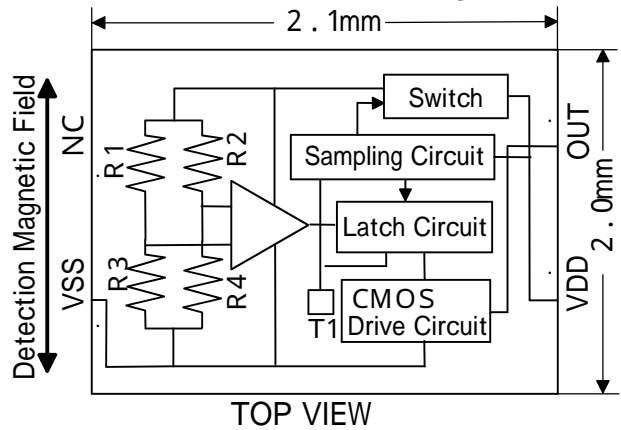

### Outline

MRX series is a monolithic IC with built-in MR magnet resistive element and CMOS switch. It becomes the switch of the noncontact of low current consumption, high sensitivity, and high reliability by combining with the magnet.

A parallel to the electrode of the package horizontal magnetic field can be detected by an arbitrary polarity (N pole S pole).

Even 1.5mT ~ 6mT can detect a wide magnetic field in the MRX series.

There are two CMOS output and **opendrain** output types that can individually detect N and S pole in MR series.

### Type Name: MRX1518HNA/Product Number Rule/List

MRX	1518:Sensitivity /Voltage	H :Operation voltage/ Output cycle	N :Package	A :Version
Anasem Product Series Name	15:1.5mT(Typ)/ 18:1.8V(Typ)	H :1.6 ~ 3.5V/25 μ s:50ms	N:SON-4/2.0 × 2.1 × 0.6mm/4L	A :CMOS/1out

### Magnetic-Electric conversion characteristic

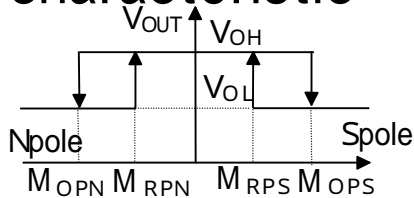

### Package

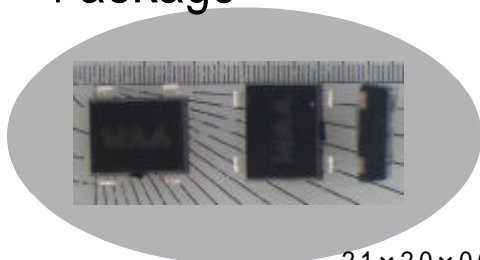

2.1 × 2.0 × 0.6mm

### Timing Chart

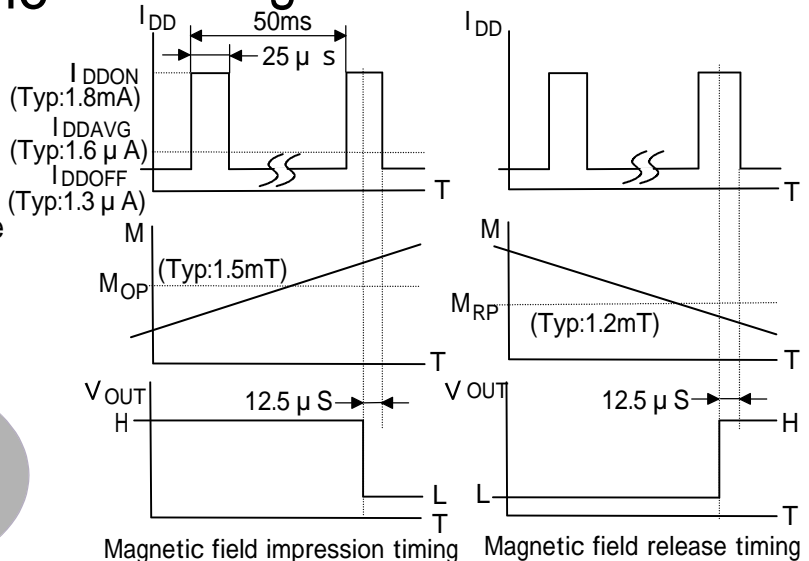

AnaSem

# Electric Characteristics

( $T_a = 25$  ,  $V_{DD} = 1.8V$ )

Item	Sign	Measurement condition	Min	Typ	Max	Unit
Operation Voltage	$V_{DD}$		1.6	1.8	3.5	V
Current consumption	$I_{AVG}$	Average Current $V_{DD}=1.8V$		1.6	3.0	$\mu A$
Output reversing magnetic induction (H L)	MOPS		(1.0)	1.5	2.2	mT
	MOPN		-2.2	-1.5	(-1.0)	
Output reversing magnetic induction (L H)	MRPS		0.8	1.2	(1.9)	mT
	MRPN		(-1.9)	-1.2	-0.8	
Width of reversing magnetic induction hysteresis	$M_{HYS}$		(0.1)	0.3	(0.8)	mT
Pulse drive cycle	$t_s$			50	90	ms
High-level output voltage	$V_{OH}$	$I_{OUT}=+1.0mA$	$0.9V_{DD}$			V
Low-level output voltage	$V_{OL}$	$I_{OUT}=-1.0mA$			$0.1V_{DD}$	V

( ) Design guarantee value

## Absolute Maximum Rating

Operating temperature range	$T_{OPR}$		-40		+85	
Storage temperature range	$T_{STG}$		-50		+125	
Absolute maximum voltage range	$V_{MAX}$		$V_{SS}-0.3$		$V_{SS}+6.0$	V
Assembly temperature condition	$T_{ASY}$	$t=\max:5\text{sec}/T_{\max}$		255	260	

## Magnetic Strength and Output Voltage

Magnet & Power	Magnet Condition	Output Voltage
Magnet=OFF Power=ON	$M=0mT$	High-Level
Magnet =ON Power=ON	$M = 2.2mT$	Low-Level
Magnet=OFF Power=ON	$M = 0.5mT$	High-Level

## Test Circuit

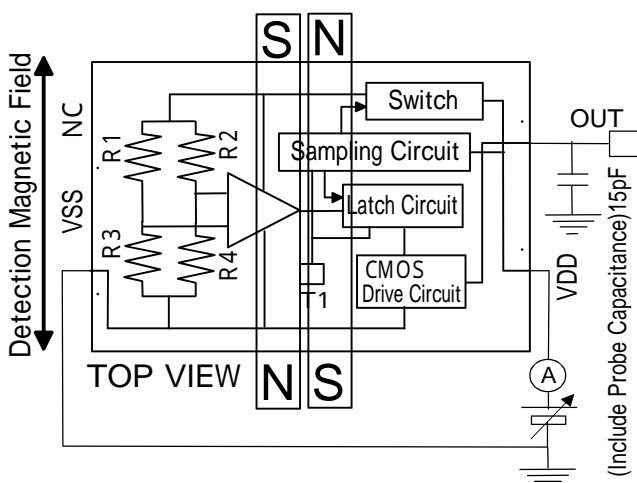

## Package Size

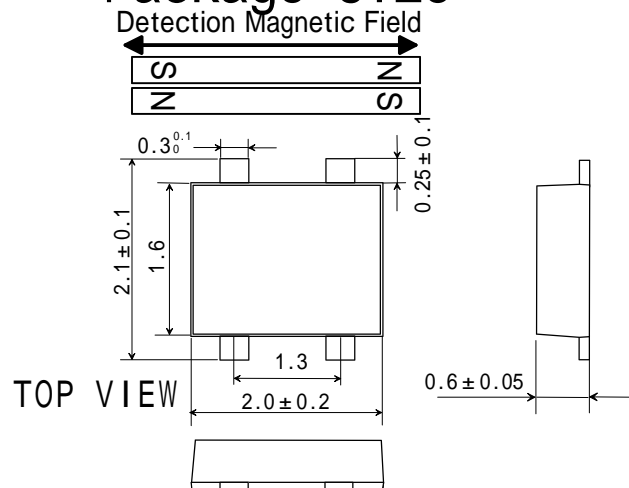

# Use Example (Cellular Phone)

## 1) Opening and shutting type detection

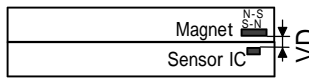

Position A  
Output= L/Level  
Magnetic Flux Density 2.2mT



Position B  
Output= L/H/Level  
Magnetic Flux Density 1.5mT

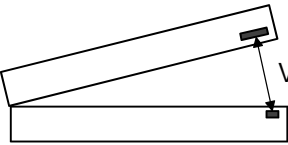

Position C  
Output= H/Level  
Magnetic Flux Density 0.5mT

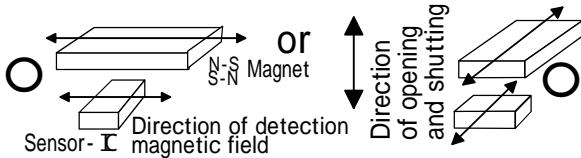

Magnet/ I Chart related to arrangement

## 3) Rotation type detection

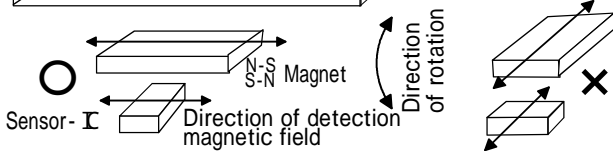
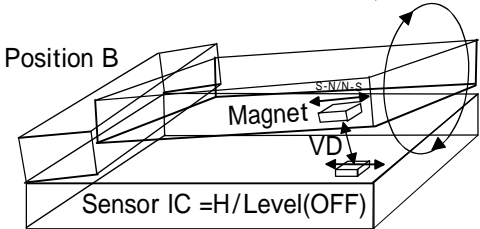
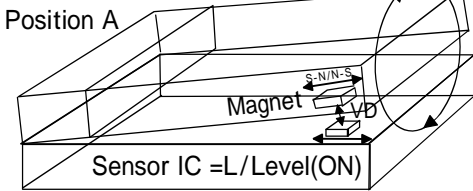

Magnet/ I Chart related to arrangement

# Magnetic field detection

When an enough magnetic induction is added in parallel to the sensor side in the direction of marking, the output is ON (Low). Magnetic field strength of each 50msec for 25  $\mu$  sec is detected. The direction of the magnetic field is detected regardless of N pole S pole. A reverse-magnetic field doesn't influence it for the detection of horizontal direction. Because the marking side and the vertical direction are perceived according to the size of the magnetic induction, it is possible to apply also to the slide type in a parallel direction and the fold type in the vertical direction.

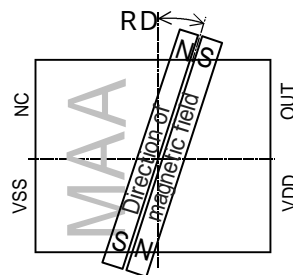
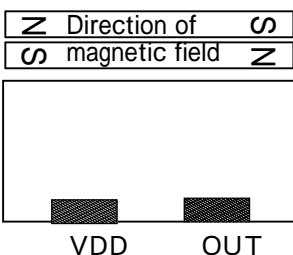

## 2) Slide type detection

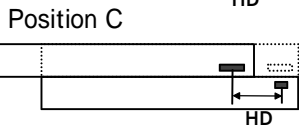
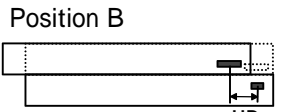
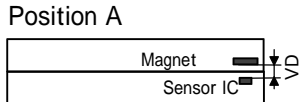

There is right-angled or parallel arrangement in the relation between the direction of the magnetic field and the direction of the slide in the slide type cellular phone. Both become switches ON in Position A, too. It is likely to become turning off in parallel arrangement in Position B. It becomes switch ON again by a reverse-magnetic field if swerving in the direction of Position C in parallel arrangement, and when the distance parts enough, it becomes switch OFF.

It doesn't become OFF by Position B in right-angled arrangement but it becomes OFF by Position C to which the distance parts enough. The meaning that prevents the malfunction recommends being designed by a right-angled method.

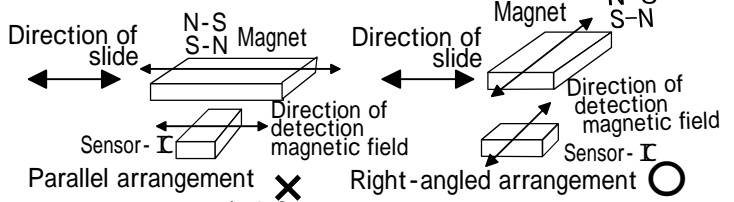

Magnet/ I Chart related to arrangement

## 4) Neodymium standard magnet vs. vertical direction (VD) direction distance

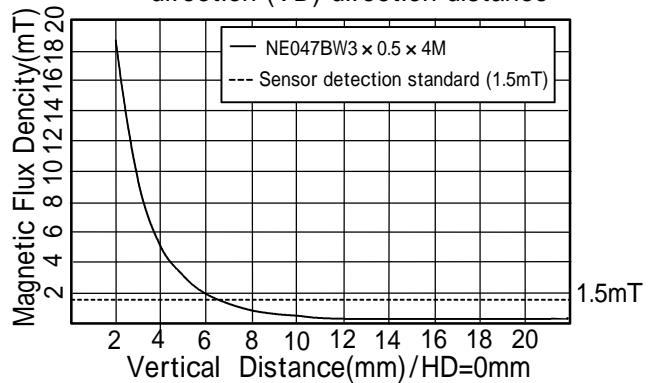

## 5) Neodymium standard magnet vs. horizontal direction (HD) direction distance

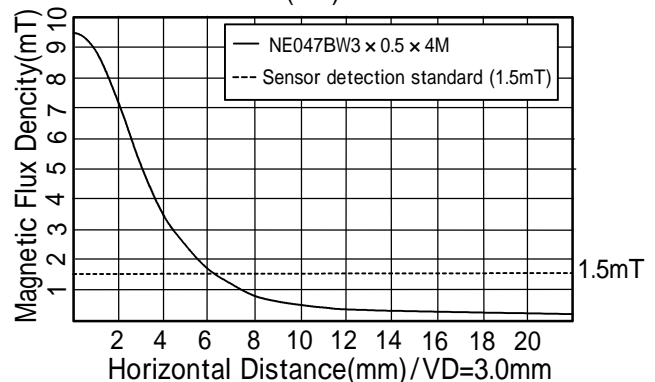

## Standard magnet specification

P point: Magnetic induction measurement position

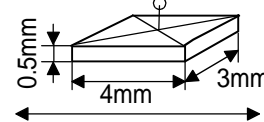

Sensor reaction/direction of magnetization

## specification

Magnet maker: TDK Corp  
Neodymium magnet  
Product number: NE047B  
W 3 x 0.5 x 4M  
Size: 4 x 3 x 0.5mm

# Electric Characteristics Data

1) Operation magnetic induction vs. power-supply voltage

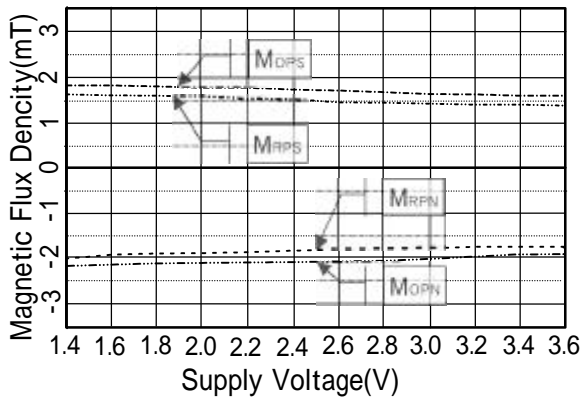

2) Operation magnetic induction vs. ambient temperature

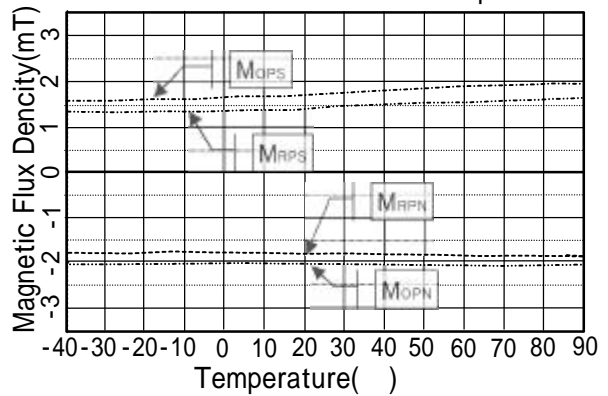

3) Current consumption vs. power-supply voltage

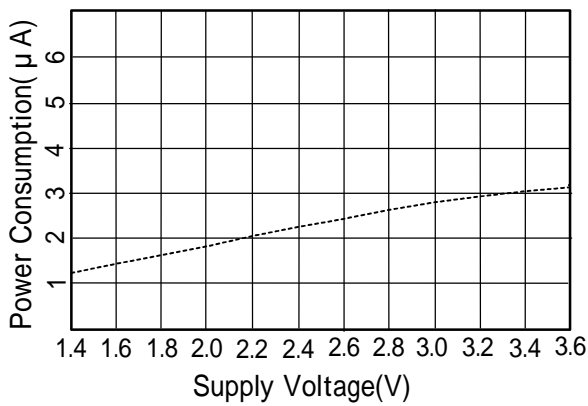

4) Current consumption (average current) vs. ambient temperature

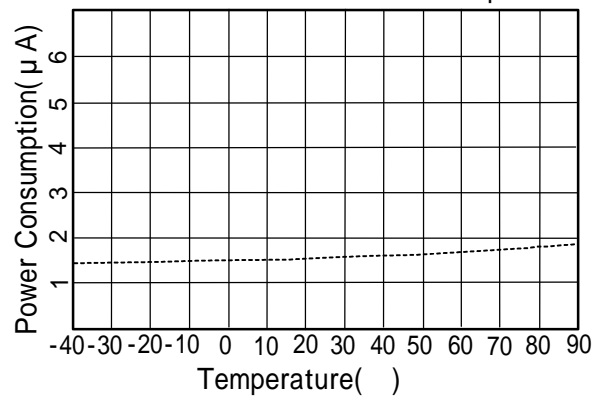

5) Detection cycle vs. power-supply voltage (Temp=25 °C)

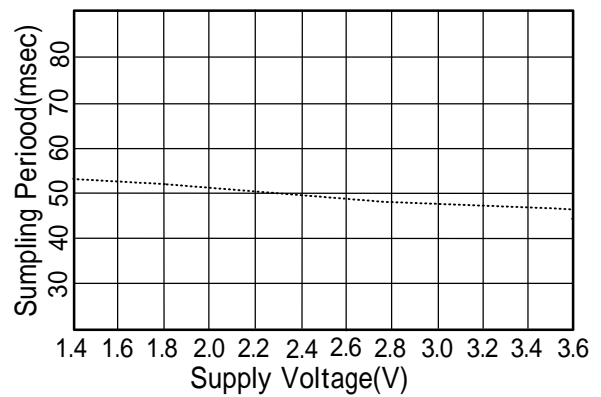

6) Detection cycle vs. ambient temperature (VDD=1.8V)

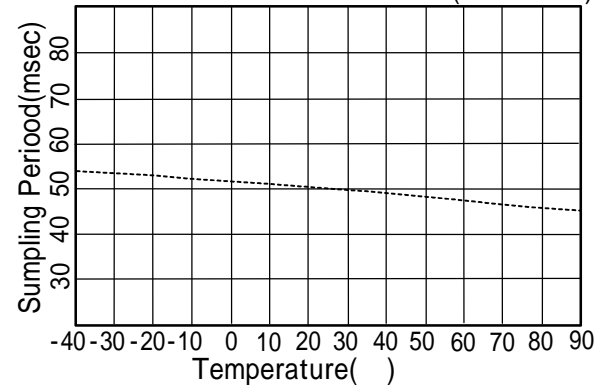

## Marking

**M A A**  
a b c  
d

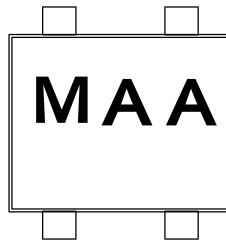

<b>a</b>	Series Name:M/MR Sensor Switch
<b>b</b>	Specification:A/A:Spec
<b>c</b>	Products Version:A/A:Version
<b>d</b>	Production Lot:Dot/Company Rule

