



Analog Semiconductor IC

MRX1533L Series

Low power consumption, 1.5mT High sensitivity
CMOS MR Magnetic Sensor Switch

Rev. E09-06

AnaSem Inc.
..... Future of the analog world



Low power consumption, 1.5mT High sensitivity CMOS MR Magnet Sensor Switch

MRX1533L Series

GENERAL DESCRIPTIONS

MRX1533L series are monolithic ICs with built-in MR magnet resistive element and CMOS switch. It becomes the non-contact switch with low current consumption, high sensitivity and reliability which is combined with magnet.

A horizontal magnetic field parallel to the electrode of the package can be detected by an arbitrary polarity. (N pole \leftrightarrow S pole)



FEATURES

- CMOS + MR monolithic structure
- Low current consumption 3.0 μ A ($V_{IN}=3.3V$, $T_a=25^{\circ}C$)
- High-sensitivity Typ. 1.5mT
- Operating temperature range $-40 \sim +85^{\circ}C$
- Operating voltage range 2.5V ~ 3.7V
- Detection pulse driving cycle Typ. 50msec with 25 μ sec width
- Magnetic direction Both direction / CMOS inverter one output
- Detection magnetic field Horizontal direction of marked side of package
(Electrode parallel both direction)
- Small package SOT-23 (2.9 \times 2.8 \times 1.1mm)

APPLICATIONS

- Detection of opening and closing : Mobile phone, Notebook PC, Microwave oven, Washing machine, Rice cooker, Refrigerator, Electronic dictionary, Digital camera, etc.
- Detection of position : Air cylinder, Antitheft window, Digital door lock, etc.
- Detection of water level : Water purifier, Humidifier, Bidet, etc.
- Detection of rotation : Water meter, Gas meter, Wattmeter, Speed meter, etc.
- Power supply switch : Cordless phone, Electric toothbrush, etc.

PRODUCTS NUMBERING GUIDE

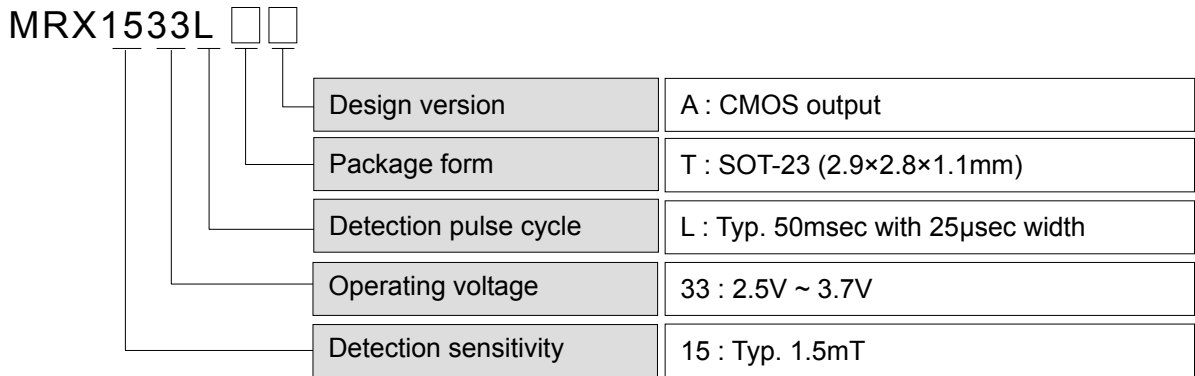

PIN CONFIGURATION / MARKING SPECIFICATION

- SOT-23

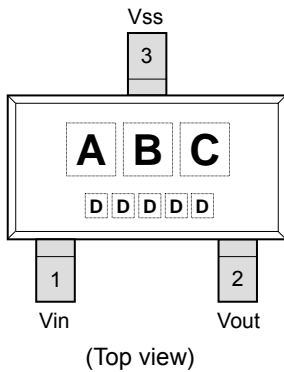

Pin Configuration

No.	Symbol	Descriptions
1	VIN	Voltage input
2	VOUT	Output
3	VSS	Power ground

Marking Specification

Code	Mark	Contents
A	M	Series name
BC	AA	Products specification & version
D	Internal rule	Lot number

BLOCK DIAGRAM

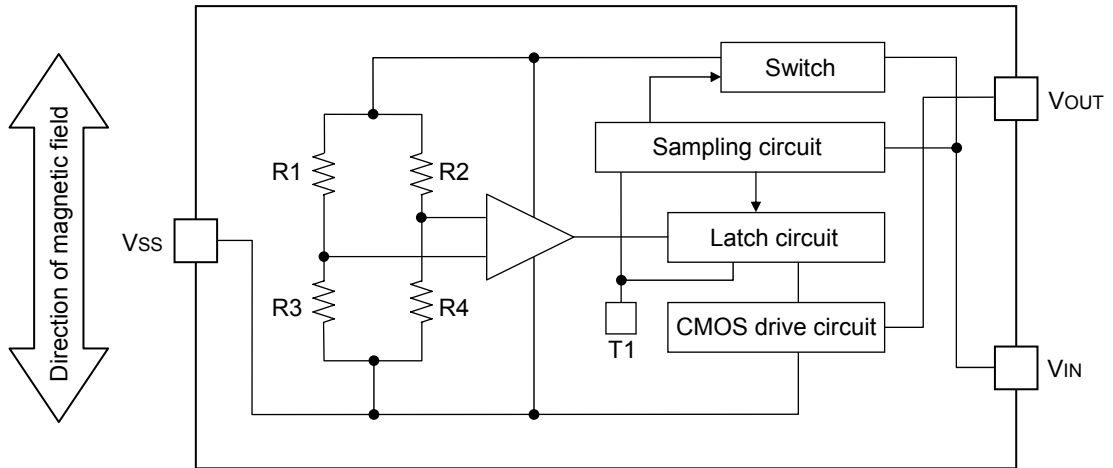

ABSOLUTE MAXIMUM RATINGS

Items	Symbol	Min.	Typ.	Max.	Conditions	Unit
Operating temperature	TOPR	-40	-	+85		°C
Storage temperature	TSTG	-50	-	+125		°C
Supply voltage	VMAX	VIN-0.3	-	VIN+6.0		V
Assembly temp. condition	TASY	-	255	260	t=max:5sec/Tmax	°C

ELECTRICAL CHARACTERISTICS

(Unless otherwise specified, VDD=3.3V, Ta=25°C)

Items	Symbol	Min.	Typ.	Max.	Conditions	Unit
Operating voltage	V _{IN}	2.5	3.3	3.7		V
Current consumption	I _{AVG}	-	3.0	5.0		μA
Detection pulse driving cycle	t _s	-	50	90		msec
“H”-level output voltage	V _{OH}	0.9V _{IN}	-	-	I _{OUT} =+1.0mA	V
“L”-level output voltage	V _{OL}	-	-	0.1V _{IN}	I _{OUT} =-1.0mA	V

MAGNETIC CHARACTERISTICS

(Unless otherwise specified, VDD=3.3V, Ta=25°C)

Items	Symbol	Min.	Typ.	Max.	Unit
Magnetic flux density at operating point (H→L)	MOPS	1.0*	1.5	2.5	mT
	MOPN	-2.5	-1.5	-1.0*	
Magnetic flux density at release point (L→H)	MRPS	0.7	1.2	2.2*	mT
	MRPN	-2.2*	-1.2	-0.8	
Width of hysteresis	MHYS	0.1*	0.3	0.8*	mT

Note : The values with [*] marks are guaranteed by design, not tested in production.

MAGNETIC-ELECTRIC CONVERSION CHARACTERISTIC

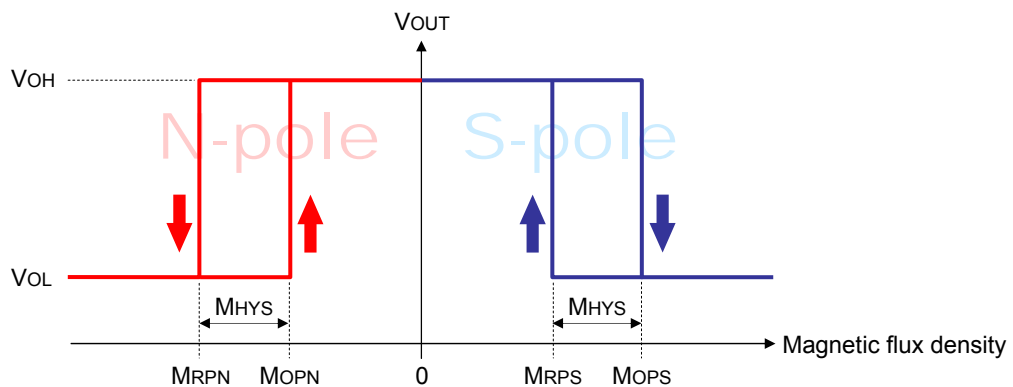

MAGNETIC FLUX DENSITY AND OUTPUT VOLTAGE LEVEL

Conditions		Output level
Magnet & Power	Magnet flux density	
Magnet = OFF / Power = ON	$M = 0\text{mT}$	High-level
Magnet = ON / Power = ON	$M \geq 2.5\text{mT}$	Low-level
Magnet = OFF / Power = ON	$M \leq 0.7\text{mT}$	High-level

DETECTION PULSE DRIVING CYCLE (SAMPLING CYCLE)

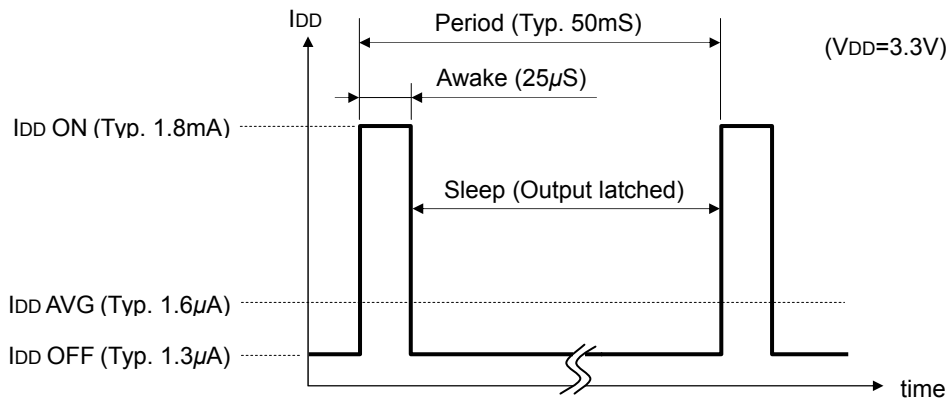

OUTPUT SWITCHING TIMING CHART

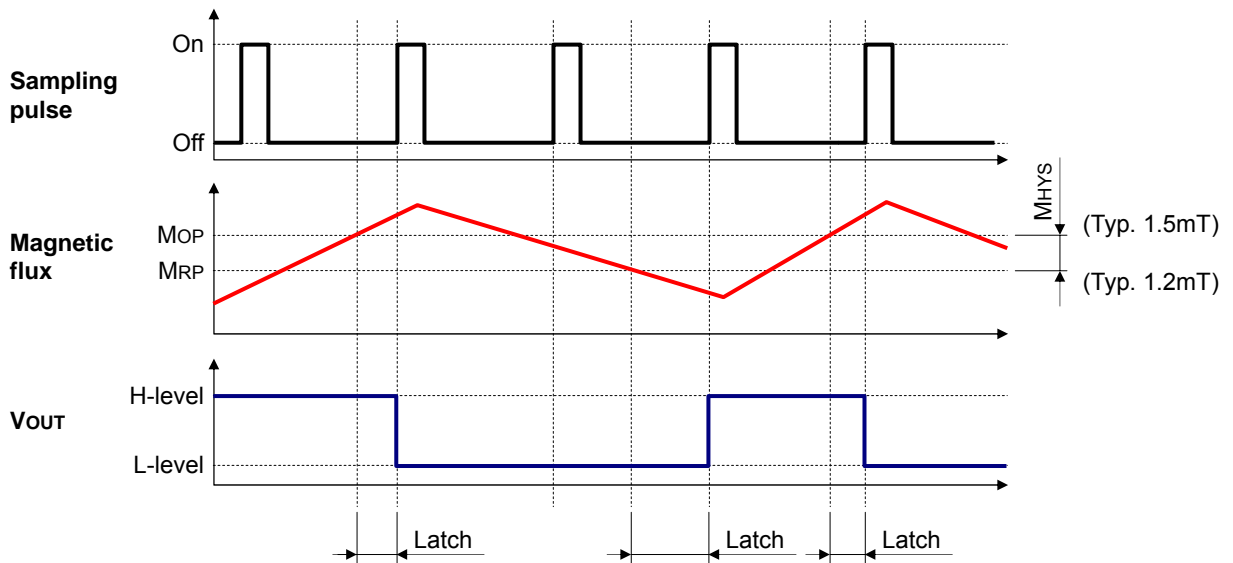

TEST CIRCUIT

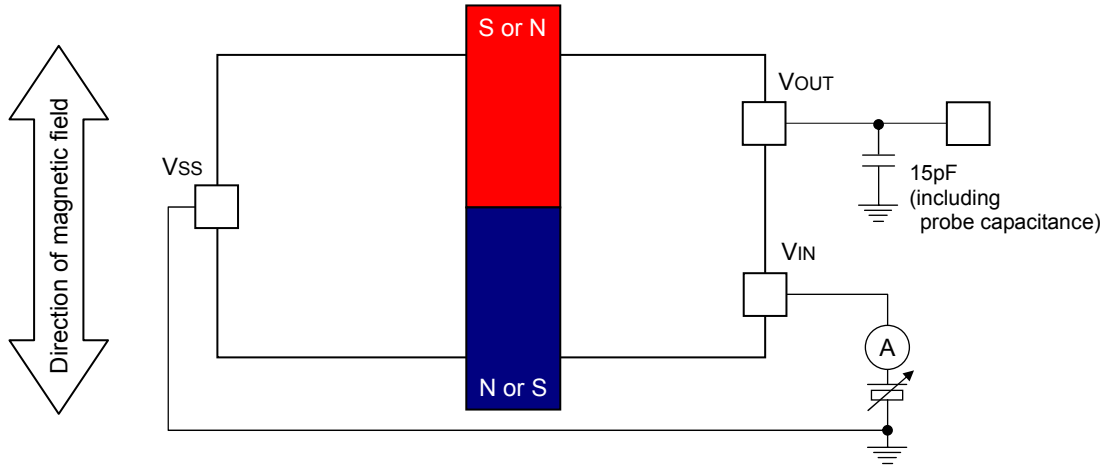

STANDARD MAGNET SPECIFICATIONS

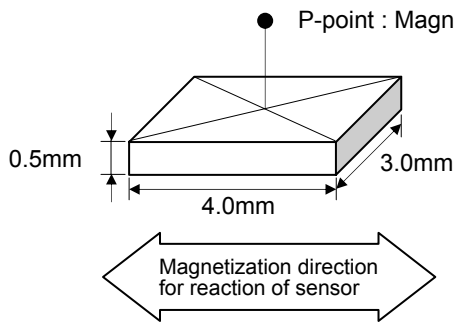

- Magnet maker : TDK Corp. / Japan
- Neodymium magnet
- Magnetic specification : NE047BW
- Size : 4.0 × 3.0 × 0.5mm

DETECTION DISTANCE SIMULATION (with standard magnet)

● Vertical direction (VD)

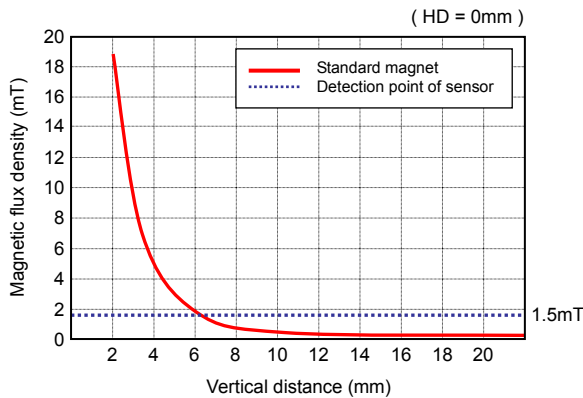

● Horizontal direction (HD)

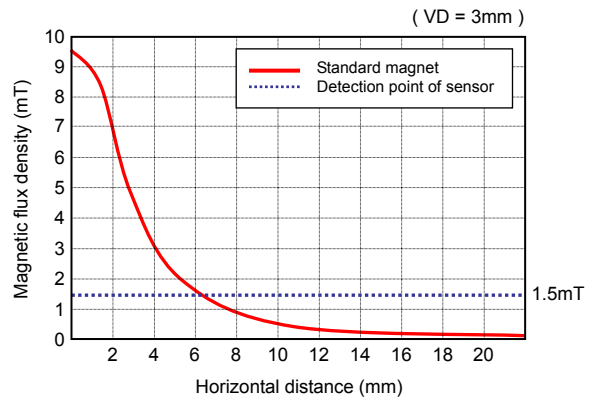

TYPICAL ELECTRIC CHARACTERISTICS

● Magnetic flux density vs. Input voltage

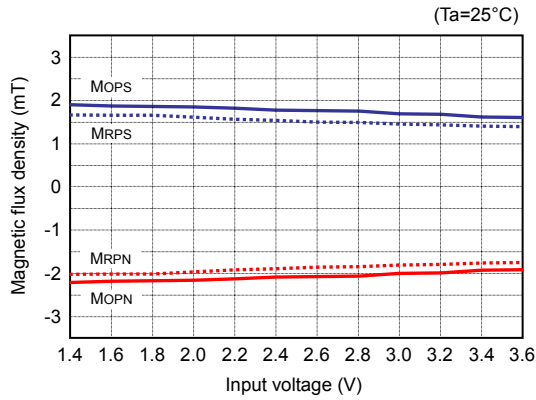

● Magnetic flux density vs. Ambient temp.

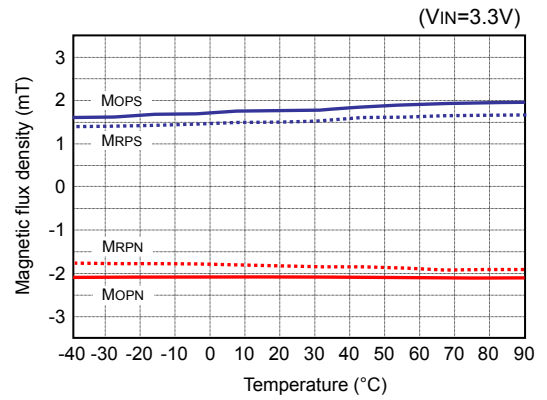

● Current consumption vs. Input voltage

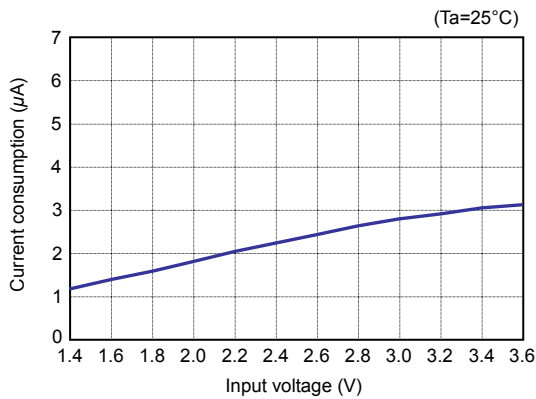

● Current consumption vs. Ambient temp.

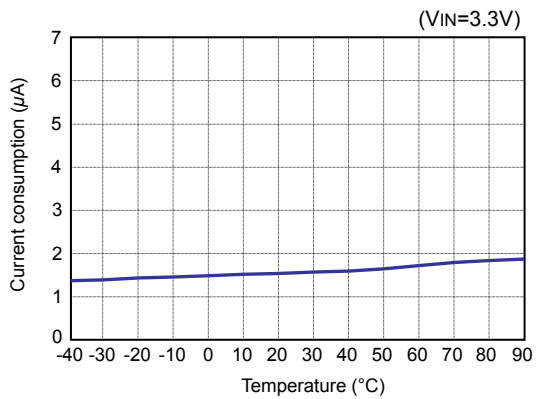

● Sampling period vs. Input voltage

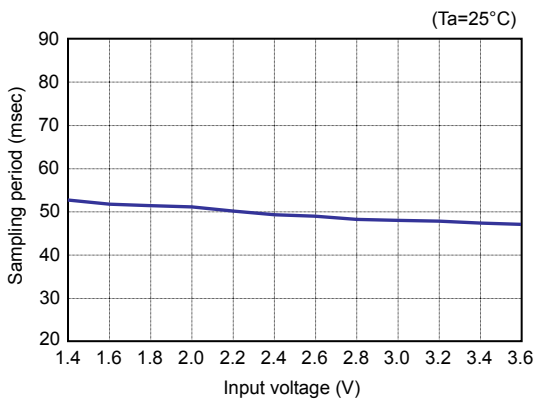

● Sampling period vs. Ambient temp.

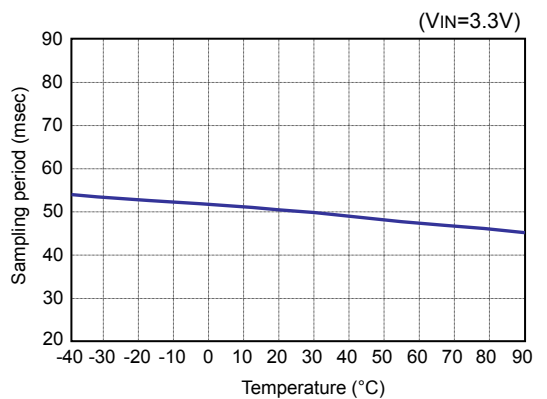

APPLICATION INFORMATIONS

- **Detection of magnetic field**

To operate output switch, the magnetic field should be applied to the sensor with sufficient magnetic flux density and correct direction. MR series are designed to be ON-state (L-level output) when the horizontal direction magnetic field is applied in parallel to the marked side of sensor, with sufficient magnetic flux (MOPS or MOPN value) regardless of polarity of magnet. Because MR series detect the horizontal direction magnetic field, it has not influence of the reverse-magnetic field. And also, MR series detect the vertical direction magnetic field according to the level of magnetic flux, so that it is possible to apply to not only slide type but also fold type.

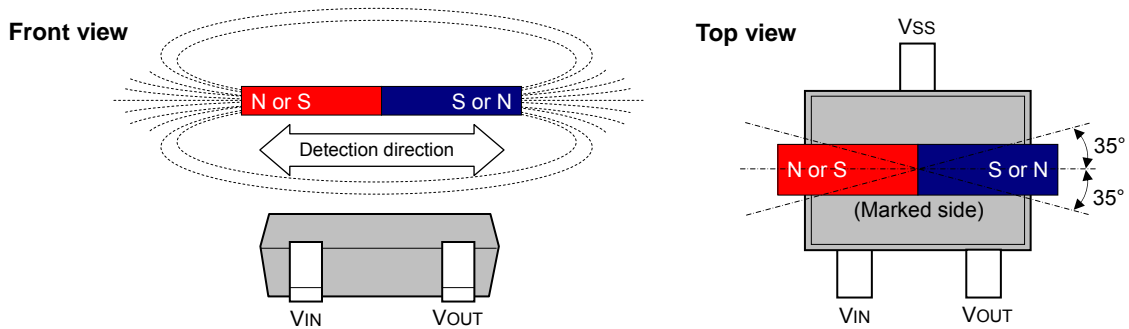

- **Application example 1 -- [Fold type]**

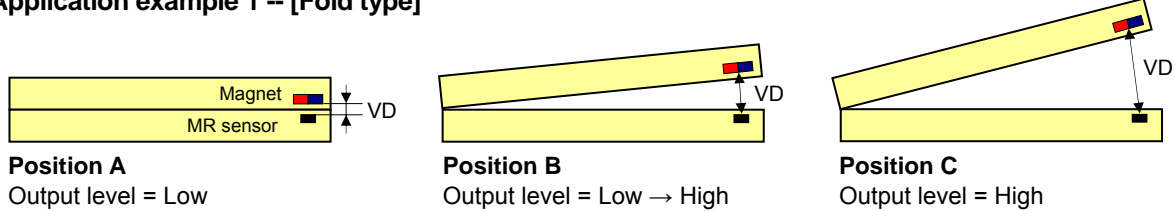

In case MR series is used for fold type cellular phone, IC sense the conditions of opening and shutting of the cover by detection of the magnetic flux according to the distance between IC and magnet. In position A, output is L-level (ON-state) because the detected magnetic flux is sufficient. The magnetic flux decrease according to the magnet is moved from IC (Position A→B). Then the IC is turned H-level (OFF-state) because the magnetic flux become MRP or less (Position B→C).

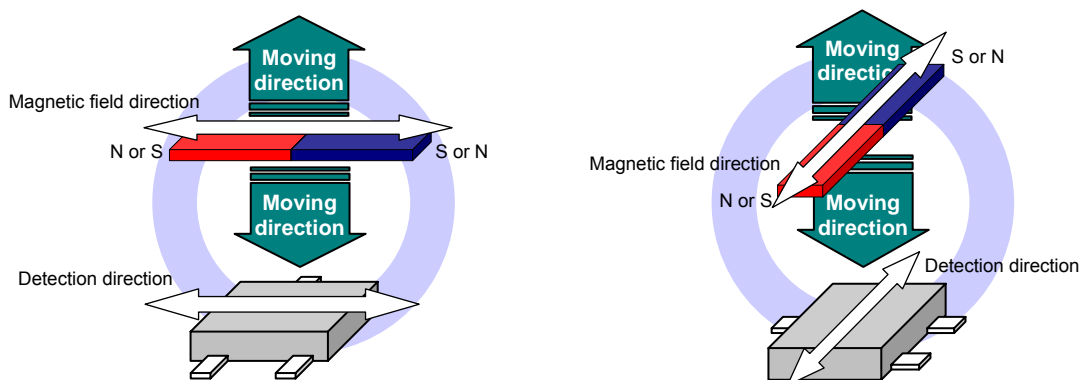

● Application example 2 -- [Slide type & Rotary type]

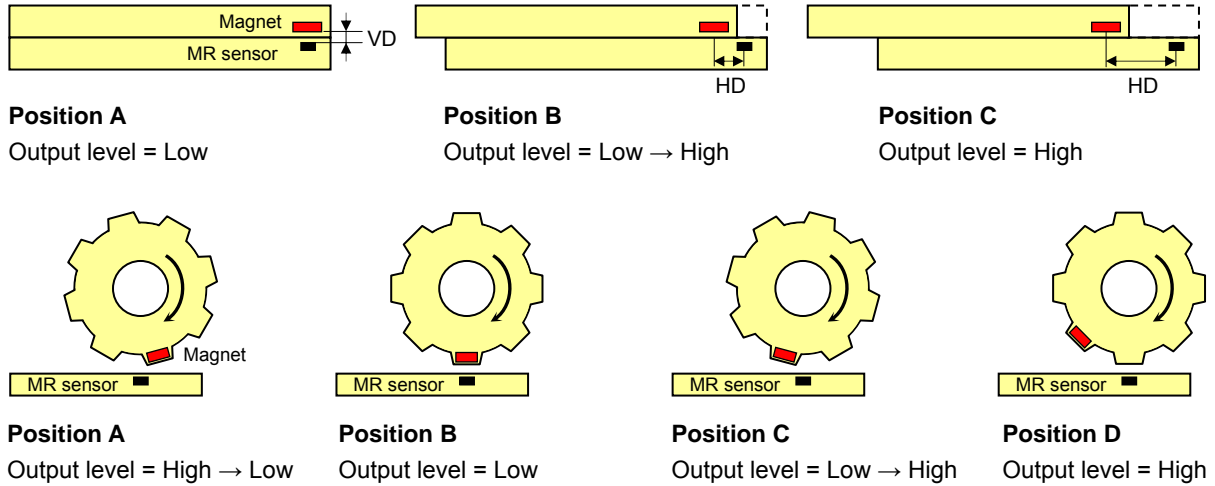

In the detection of the slide type, there are two ways of arrangement of magnetic field detecting direction against moving direction. One is parallel and another is cross with moving direction. In case of parallel positioning of magnetic field with moving direction [arrangement 1], the output of IC might be L-level (ON-state) → H-level (OFF-state) → L-level (ON-state) → H-level (OFF-state) due to reverse-magnetic field.

To prevent from this malfunction, it is recommended to arrange the detection direction of sensor and magnetic field to be crossed with moving direction of cover [arrangement 2].

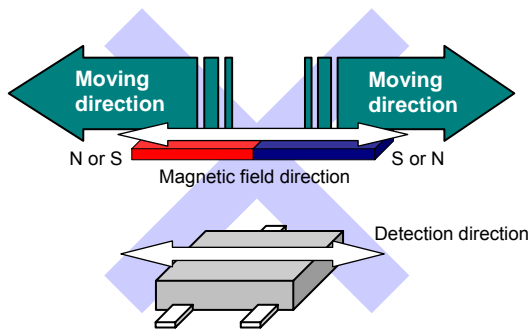

[Arrangement 1]
Parallel the direction of detection magnetic field with the moving direction

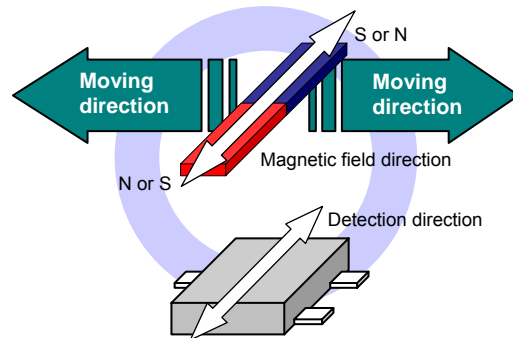

[Arrangement 2]
Cross the direction of detection magnetic field with the moving direction

PACKAGE DIMENSIONS (SOT-23)

(Unit : mm)

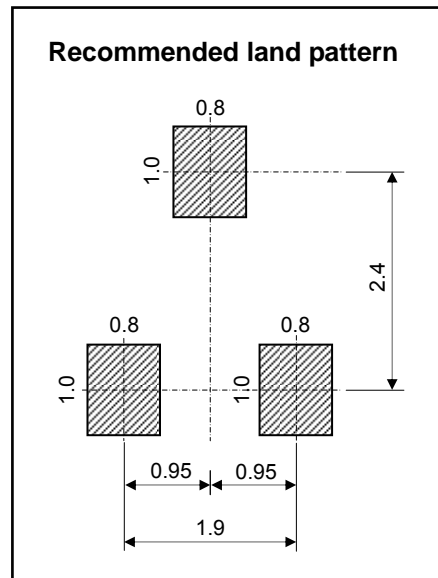
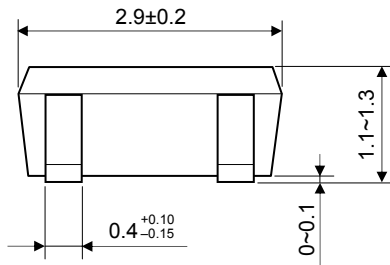
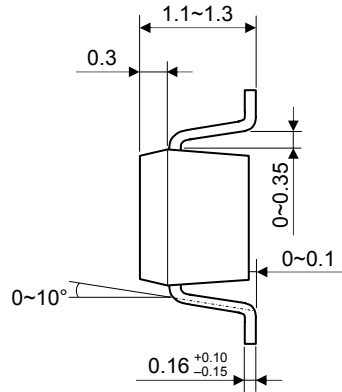
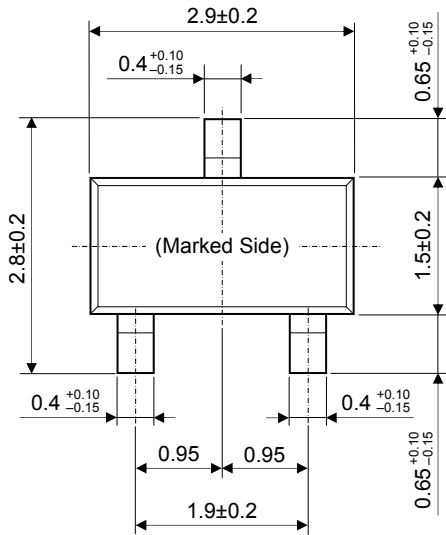

TAPING AND LOADING SPECIFICATIONS (SOT-23)

(Unit : mm)

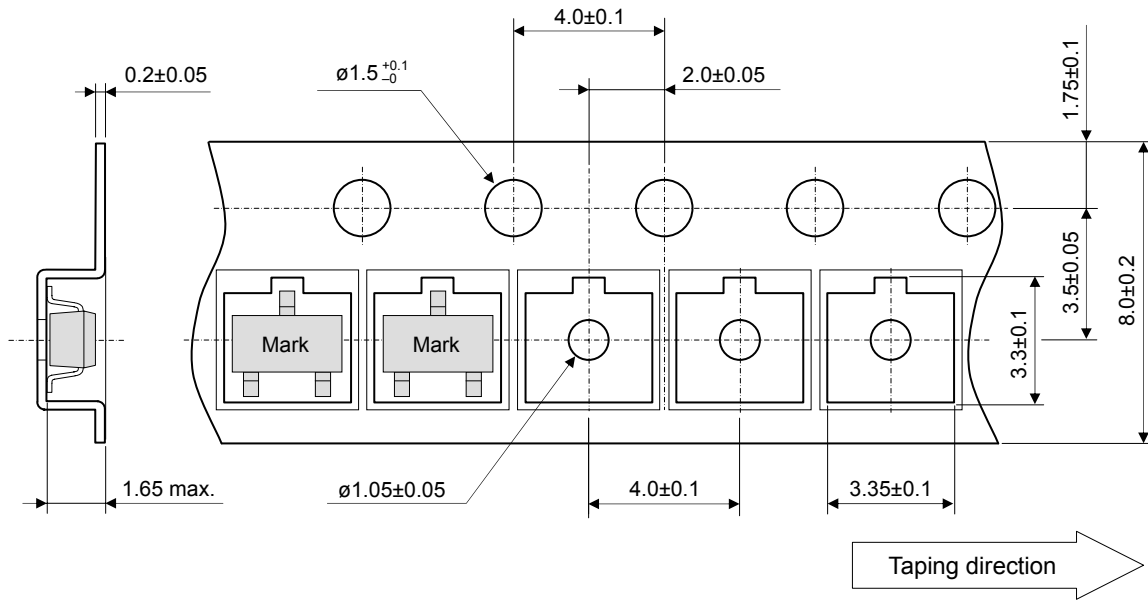

REEL DIMENSIONS (SOT-23)

(Unit : mm)

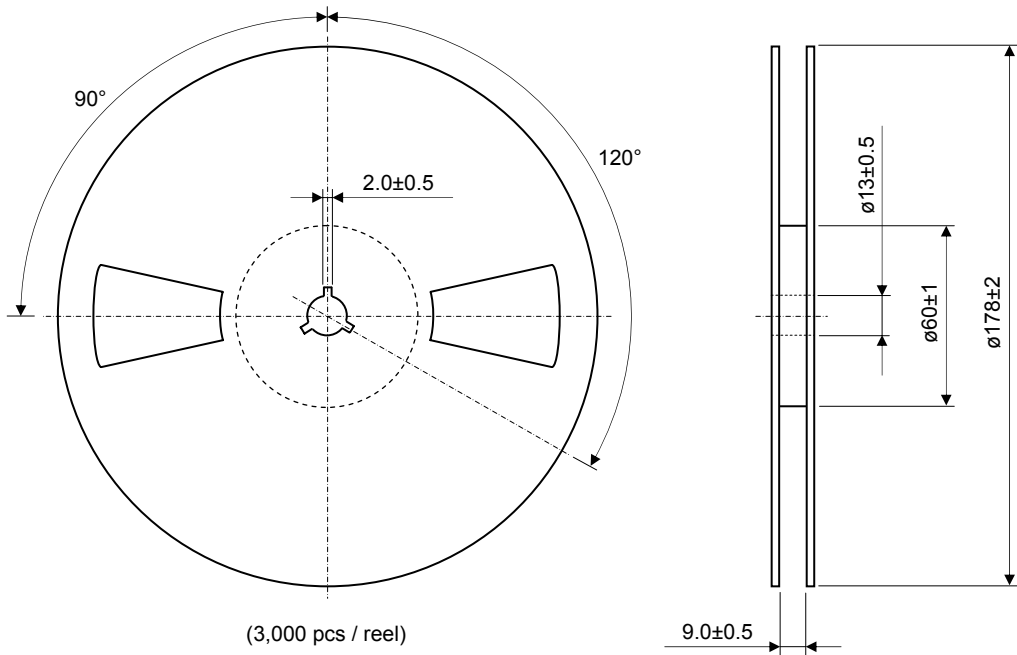



AnaSem Inc. may change the products described in this data sheet, or may discontinue production or services without any notice in order to supply the best products through improve the design and performance. Customers are recommended to obtain the latest data or information before placing orders in order to make sure the data or information required is the newest. It is necessary for customers to fully understand the products described in this data sheet and to use it in accordance with its specifications. The products described in this data sheet are not intended to use for the apparatus which have influence on human lives due to the failure or malfunction of the products. AnaSem Inc. is not responsible for any support to customer's application, product design, software performance, patent infringement or service. AnaSem Inc. does not disclose or imply a guarantee or description about being licensed based on patents, copy-rights, circuit location license, or other intellectual properties associated with the devices or combinations in which the products or service of AnaSem Inc. are used or can be used, or which cover the methods. Customers should not export, directly or indirectly, any products without obtaining required licenses and approvals in advance from appropriate government agencies.

ANASEM INC. _____